

Microcontrollers

ApNote

AP2921

On-Board Communication via CAN without Transceiver

This application note describes a possible communication between controller devices with CAN modules (such as Siemens C515C, C167CR, SAE81C90), e.g. in multi processor systems, where the devices are on the same card or in the same rack. No CAN transceiver devices are used for this application.

Author : Dr. Jens Barrenscheen / HL MC PD Microcontroller Product Definition

The proposed alternative structure permits communication between controller devices with CAN modules (such as Siemens C515C, C167CR, SAE81C90), e.g. in multi processor systems, where the devices are on the same card or in the same rack. If the standard serial channels are used for other purposes, the CAN module can easily be used for data exchange. Furthermore, the proposed solution reduces the number of required components and may have advantages compared to dual-ported RAM. Contrary to the standard CAN bus structure with the two CAN bus lines CAN_H and CAN_L (see **figure 1**), no CAN transceiver devices are used.

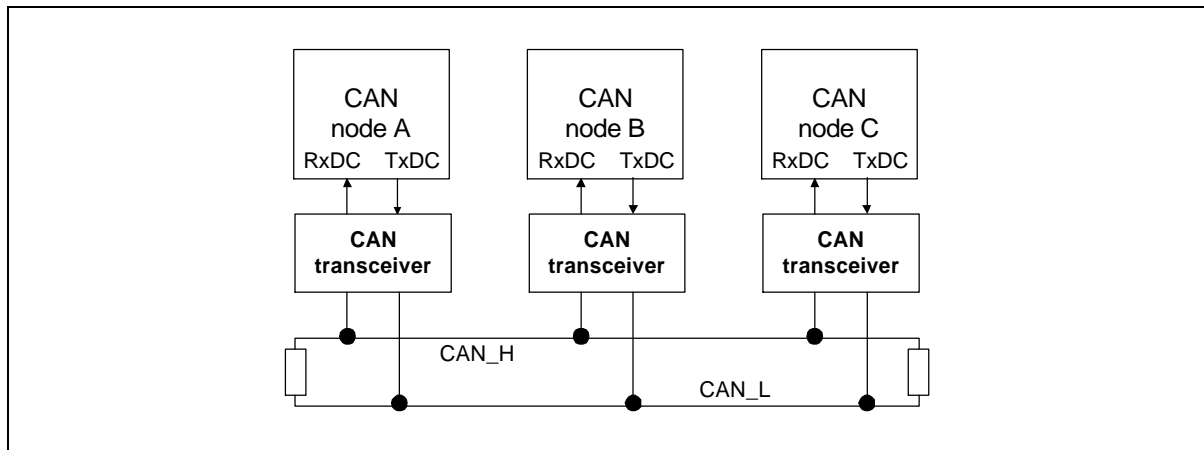

Figure 1 :
Standard connection to CAN bus via CAN transceiver

The alternative solution is based on a wired-or structure (see **figure 2**). All TxDC output lines (push-pull) are connected to a single data line via fast diodes to avoid short circuits at the output pins. The RxDC inputs are directly connected to this line, which is pulled to +5V by a pull-up resistor to get the passive "1"-level. An active dominant „0“-level at an output pin forces the data line to "0"-level, allowing standard bus arbitration and multi master functionality. It is very important that the current at one port pin does not exceed 1.6 mA.

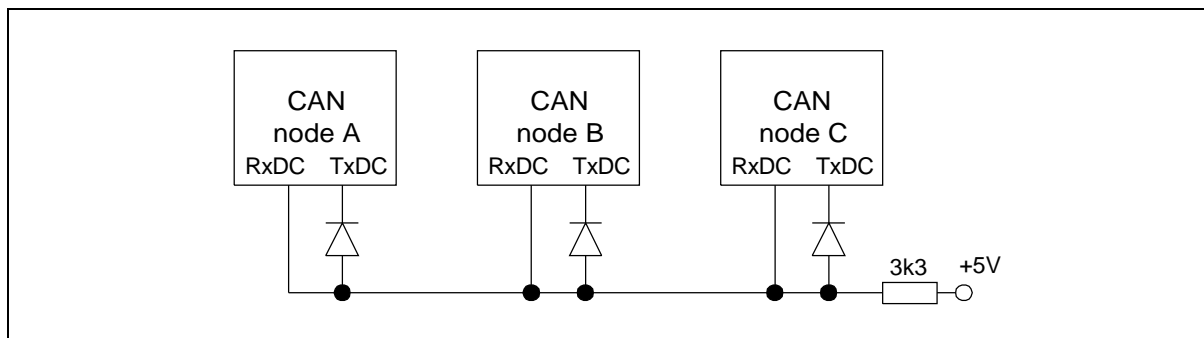

Figure 2 :
Connection of CAN nodes without CAN transceiver

As no CAN transceiver is used, the maximum wire length is limited ($\ll 1\text{m}$) and disturbances due to noise can occur. If these aspects are respected, this structure can easily be used to connect two or more controller devices via one signal line. This application has been developed as an alternative approach towards on-board data exchange and not to replace the standard CAN bus.